



 HammerheadArmor  Hammerheadarmor  HammerheadOff-RoadArmor

# 2021-20XX CHEVROLET TAHOE/SUBURBAN GUARDIAN SERIES PUSH BUMPER



## SAFETY

**Know safety, no injury. Know injury, no safety. ~Author Unknown**

If there are any questions, call 1-855-HHTOUGH



**READ ALL SAFETY INSTRUCTIONS BEFORE INSTALLATION**

- FOLLOW ALL INSTRUCTIONS FOR PROPER ASSEMBLY
- WEAR APPROPRIATE EYE PROTECTION
- EXERCISE CARE WHEN LIFTING COMPONENTS
- USE APPROPRIATE TORQUE FOR BOLTS
- RE-TORQUE HARDWARE AT EVERY OIL CHANGE.

BOLT DIAMETER (INCH)	THREADS PER INCH	TORQUE (POUND - FEET)
1/4	20	7
5/16	18	14
3/8	16	25
7/16	14	40
1/2	13	60
9/16	12	88
5/8	11	120
3/4	10	200
7/8	9	302
1	8	466

BOLT DIAMETER (mm)	THREAD PITCH (mm)	TORQUE (POUND-FEET)
6	1.0	7
8	1.25	16
10	1.5	32
12	1.75	55
14	2.0	88
16	2.0	140
18	2.5	195
20	2.5	275
22	2.5	375
24	3.0	475

	<p><b>WARNING: Cancer and Reproductive Harm</b></p> <p><a href="http://www.P65Warnings.ca.gov">www.P65Warnings.ca.gov</a></p>
---	---

**I. PARTS LIST**

Note: Brush guard configuration may differ.

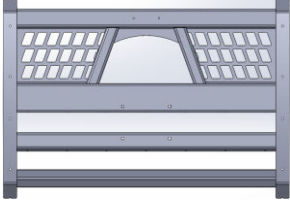
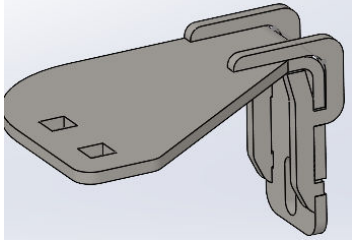
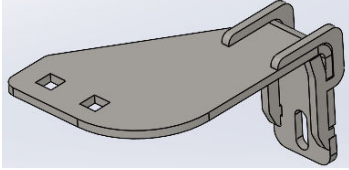
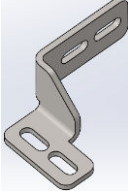
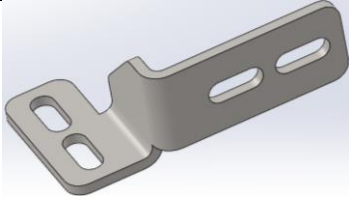
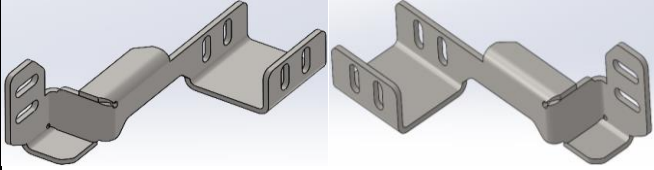
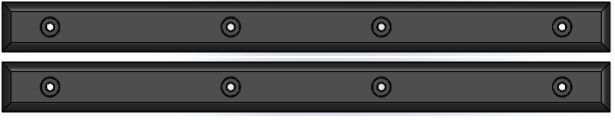
ITEM 1	PURSUIT SERIES GG	QTY. 1	ITEM 2	L UPPER FRAME MOUNT WELDMENT	QTY. 1
					
ITEM 3	R UPPER FRAME MOUNT WELDMENT	QTY.1	ITEM 4	LEFT UPPER OUTER MOUNT	QTY. 1
					
ITEM 5	RIGHT UPPER OUTER MOUNT	QTY. 1	ITEM 6	HARDWARE KITS	
				<ul style="list-style-type: none"> <li>✓ <b>HARDWARE KIT #208</b> (60K-56-0208)</li> <li>✓ <b>HARDWARE KIT #219</b> (60K-56-0219)</li> </ul>	
ITEM 7	L AND R LOWER FRAME MOUNT	QTY. 2	ITEM 8	UHMW TRIM	QTY. 2
					

**REMOVE CONTENTS FROM BOX AND VERIFY ALL PARTS ARE PRESENT.**

If there are any questions, call 1-855 HHTOUGH or email [HHORDERS@hammerheadarmor.com](mailto:HHORDERS@hammerheadarmor.com)

**II. TOOL LIST**

- ✓ A good friend
- ✓ Basic tool set
- ✓ Blue masking tape
- ✓ Torx 15 bit
- ✓ 7mm socket
- ✓ 10mm socket

- ✓ 15mm socket
- ✓ 18mm socket
- ✓ 3/4" socket
- ✓ Ratchet
- ✓ Ratchet extension
- ✓

### III. VEHICLE PREPARATION

1. Park vehicle on level surface.
2. Engage parking brake and disconnect battery.
3. Using blue masking tape, mask along the profile of your truck above the bumper. This will help protect your truck from any accidental scratches.

### IV. REMOVAL OF BUMPER

1. Open the hood and find the (9) plastic rivets found on top of the grille shroud. Using a trim removal tool pry the head and body of the rivets out. Set plastic rivets aside to be reused.

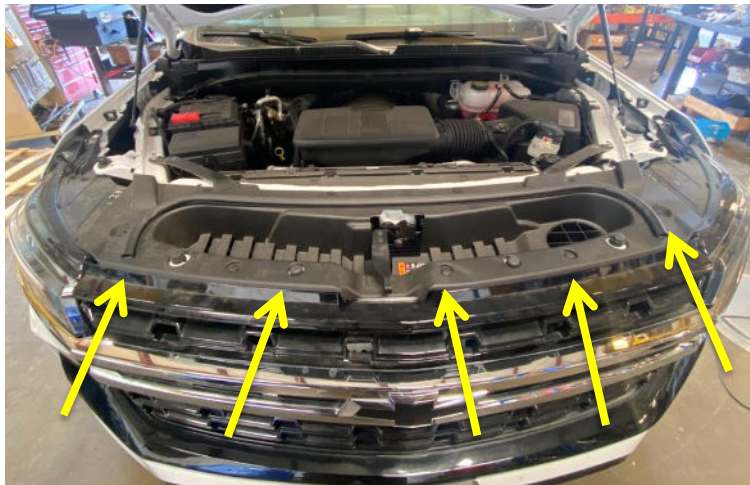

2. On each side of the vehicle, locate the (6) T15 screws (3 per side). This will give you access to the (6) 7mm bolts (3 per side) holding the fender onto the body. Remove these and set aside for reuse.



- Using a T15 bit, locate the two screws at the back of the hood release lever. Remove the screws and lever so the upper panel will lift off the vehicle. Then reinstall the two T15 screws and lever in case the hood closes during install.



- On the bottom of the bumper, locate the (6) M7 bolts in the center and (4) T15 screws on each side in front of the wheels. Use a 7 mm wrench or socket to remove the (6) M7 bolts and a T15 to remove the screws in front of each wheel. Set hardware aside to be reused.



- Next with a 10mm socket or wrench begin by removing the (6) 10mm bolts holding the top of the grille to the radiator support. With the bolts removed, remove the bumper by lifting up the top of the grille. There are two clips holding the bumper in place, lifting up and pulling forward on the bumper to remove it from the vehicle. Remember to unplug any wiring harness.



6. With the bumper removed, you can now remove the lower air guide. The lower air guide is held in place on the bottom with (4) plastic rivets. Using a trim removal tool remove the inner plug then the outer plug will pop out.



- Using a 15 mm socket, remove (2) hex head bolts (2 per side) from the bumper bar as shown below. Set hardware aside for reuse. Note the bumper bar will stay installed for this installation procedure.

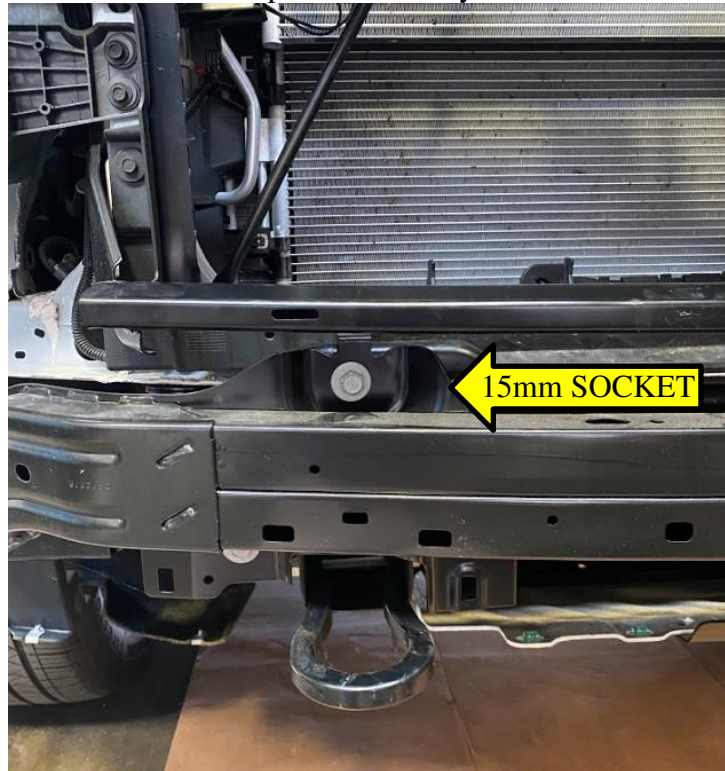

- Using an 18mm socket and wrench remove the (4) 18mm bolts (2 per side) securing the tow hooks to the frame. Keep the tow hooks and hardware for push bumper install.



## V. INSTALLATION OF HAMMERHEAD PUSH BUMPER

1. Lay push bumper face down on a carpeted surface or a piece of cardboard. Install all lights in push bumper with brackets and hardware provided by light manufacturer.
2. Using a 15mm socket or wrench install the upper frame mount brackets on the frame horns using the 15mm hardware removed previously. Repeat on the opposite side. Note: upper frame mounts need to curve away from each other. As shown below.

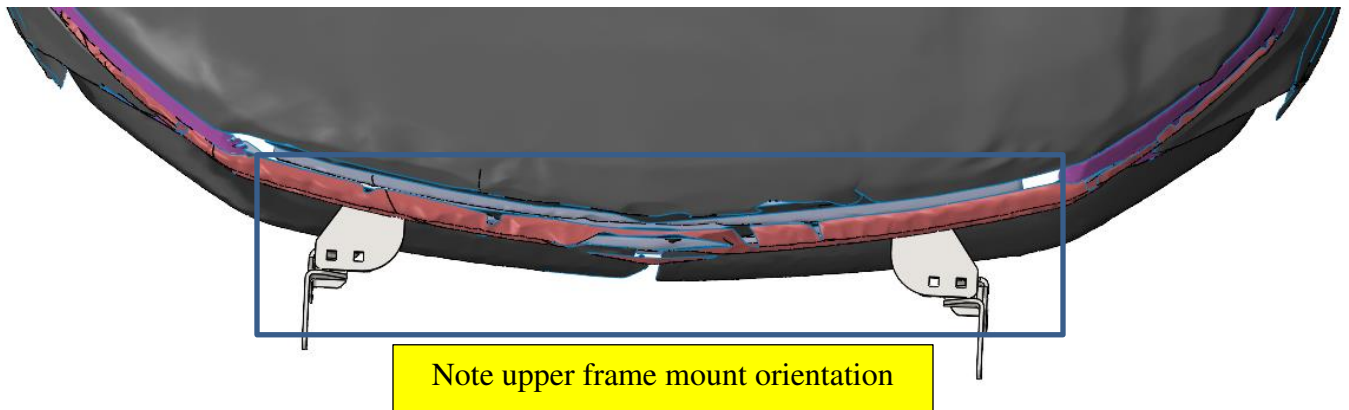
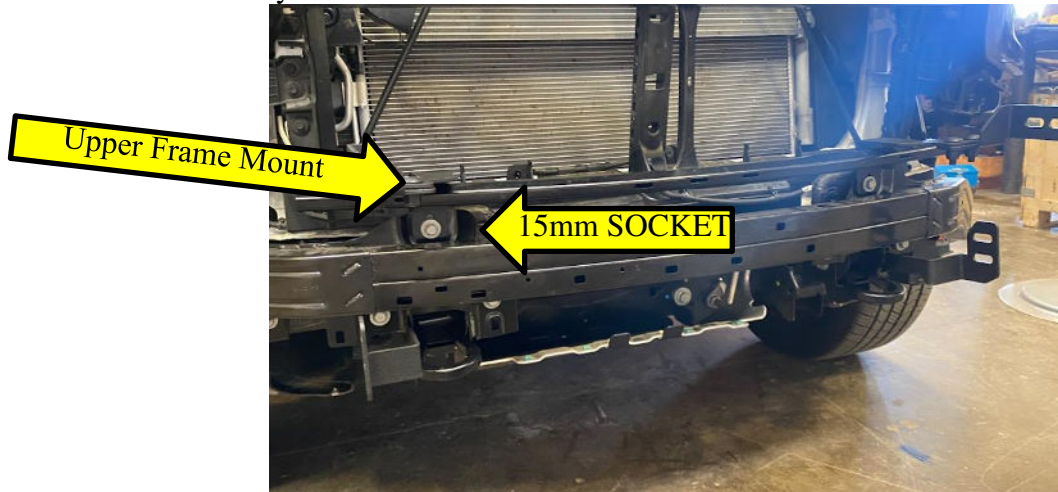

3. Next, install both lower frame mounts with the same orientation as the upper frame mounts. Using an 18mm wrench and socket install the lower frame mounts and factory tow hooks using OE hardware.



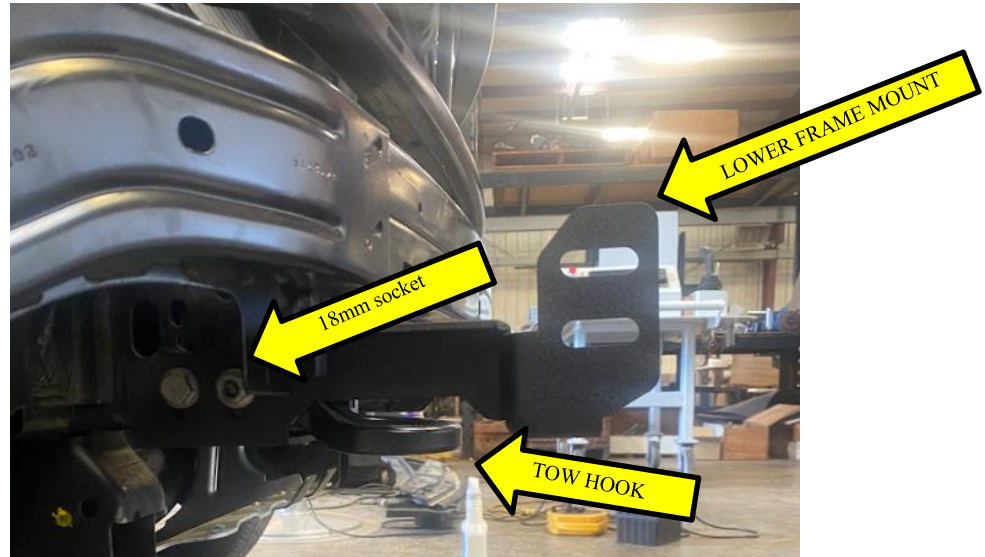

4. Next, lay the bumper on a carpeted surface or on a piece of cardboard. From the backside of the bumper using a knife or cutting device, trim out half of the tow hook holes towards to outside of the vehicle. See image below for reference. Repeat on other side.

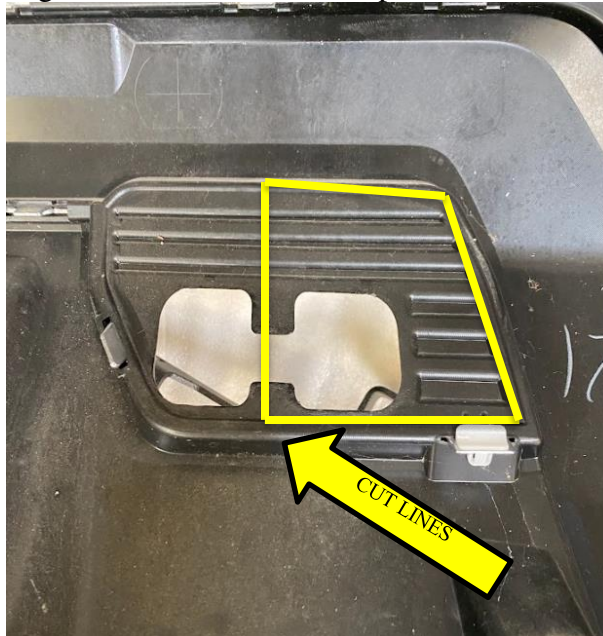

5. Next, using a knife or cutting device, trim the grille openings for the upper frame mounts. The bottom outside tabs on the grille need removing so the upper frame mounts can pass through the grille.



6. Now the slots are complete, use a hoist or a friend to lift bumper to be snapped back on. Align the bumper slots to the push bumper mounts and slide the bumper on. Start attaching the bumper from the center and working your way out. This allows for the clips to line back up properly making sure the bumper is on correctly. Work your way out to the fender flairs.



7. Using a 7mm wrench or socket reinstall the (6) flange bolts (3 per side) from the fender wheel well to the bumper. Followed by installing the (6) T15 (3 per side) screws in the inner fenders as well.



8. Using a 7mm wrench or socket and a T15 bit re-install the (8) M7 bolts and (6) T15 screws in the bottom of the bumper. Note: Start in the center of the bumper and work out towards the wheels.



9. Using a 10mm socket or wrench, reinstall the (6) 10mm bolts on the top of the grille



10. Next, Using a T15 bit remove the (2) T15 screws connecting the hood latch release lever again, Note: Do not shut the hood before reattaching the hood latch release lever



9. Next, Reinstall the (9) push rivets back into the top grille shroud.

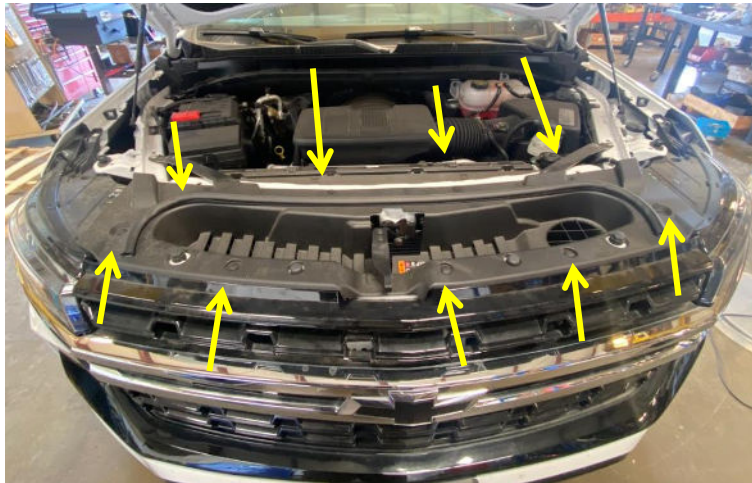

10. Next, install the upper outer frame mounts to the protruding upper frame mounts from the grille. Using hardware from hardware kit#208 with a 3/4" socket. Install the upper outer frame mounts as shown below. Do not fully tighten yet.

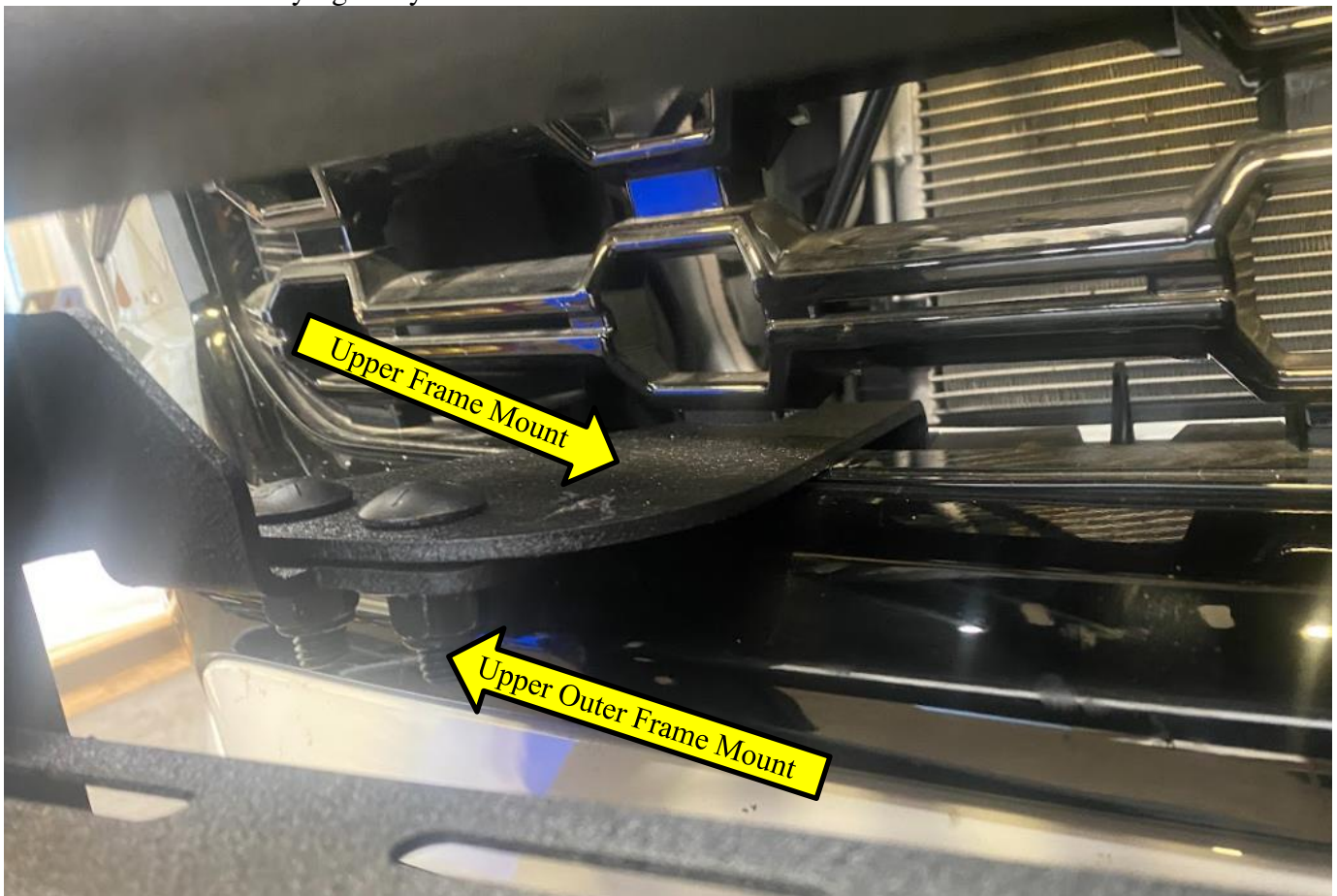

11. Using a hoist or a few friends, attach push bumper to push bumper mounts using hardware kit #208. Start all bolts before aligning push bumper. Align push bumper to a minimum of ¼” from plastic fascia. When truck flexes off-road, this distance allows your push bumper and body to have clearance. Fully tighten push bumper to push bumper mount bolts with ¾” socket.



**Congratulations! Your product installation is now complete.  
Thank you for your purchase!**