

2000-2005 Excursion

REAR BUMPER INSTALLATION INSTRUCTIONS



SAFETY

Know safety, no injury. Know injury, no safety. ~Author Unknown

- **READ ALL SAFETY INSTRUCTIONS BEFORE INSTALLATION**
 - FOLLOW ALL INSTRUCTIONS FOR PROPER ASSEMBLY
 - WEAR APPROPRIATE EYE PROTECTION
 - EXERCISE CARE WHEN LIFTING COMPONENTS
 - USE APPROPRIATE TORQUE FOR BOLTS
 - BLUE THREAD LOCKING COMPOUND IS RECOMMENDED ON ALL BOLTS

California Proposition 65



WARNING

Cancer and Reproductive Harm
www.P65Warnings.ca.gov

DO NOT PAINT OVER THIS LABEL. REPLACE IF DAMAGED OR LOST

DKB150_00



2000-2005 Excursion

Suggested Torque Values For Steel Grade 5 Standard Bolts		
BOLT DIAMETER (INCH)	THREADS PER INCH	TORQUE (POUND - FEET)
1/4	20	7
5/16	18	14
3/8	16	25
7/16	14	40
1/2	13	60
9/16	12	88
5/8	11	120
3/4	10	200
7/8	9	302
1	8	466

Suggested Torque Values For Steel Grade 8.8 Metric Bolts		
BOLT DIAMETER (mm)	THREAD PITCH (mm)	TORQUE (POUND-FEET)
6	1.0	7
8	1.25	16
10	1.5	32
12	1.75	55
14	2.0	88
16	2.0	140
18	2.5	195
20	2.5	275
22	2.5	375
24	3.0	475

I. PARTS LIST

ITEM NO.	QTY.	PART NUMBER	DESCRIPTION	
1	4	316-01-0005	1.25" PLUG BT-FLUSH LDPE BLACK	-
2	2	316-56-0001	1.25" PLUG IN LKING HOLE PLUG	-
3	1	443-01-0086	LICENSE PLATE MOUNTING KIT	-
4	1	601-56-2522	LEFT FRAME MOUNT	-
5	1	601-56-2523	RIGHT FRAME MOUNT	-
6	1	60K-56-0001	HARDWARE KIT #1	-
7	1	60P-56-0502	600-56-0502 POLISHED	-



2000-2005 Excursion

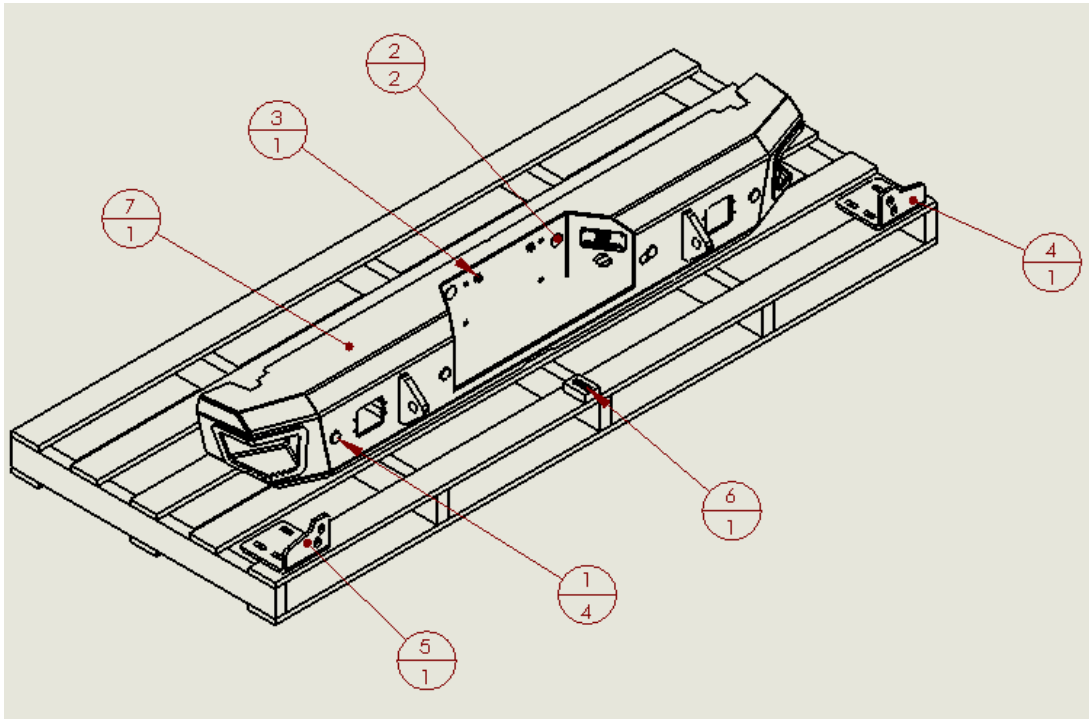

II. TOOL LIST

1. A good friend
2. Basic tool kit
3. 3/4" wrench
4. 3/4" socket
5. 8mm socket
6. 21mm socket

III. REMOVAL OF OEM BUMPER

1. Using an 8mm socket, remove two screws that attach license plate.
2. Unplug OE sensor and license plate harness.





2000-2005 Excursion

3. Crush hazard. Do not get under the bumper. It will be ready to come off when this step is complete. Excursion will remove in the same manner, but the mounts are shorter.
Using 21mm socket, remove two nuts attaching OE rear bumper bracket. (both sides) Hold bumper and push bolt strips through holes. Remove OE bumper and set face down on cardboard.



4. Carefully remove OE sensors, wiring harness, and license plate lights from OE bumper. They will be reused. If you have sensors, you will need to purchase new retainers from Ford. Part # CC3Z-15K861-AA



IV. INSTALLATION OF HAMMERHEAD BUMPER

1. Install new rear park assist sensor retainers and sensors into Hammerhead bumper. Install aftermarket flush mount lights with provided hardware.



2000-2005 Excursion

2. Install license plate lights and wiring harness in Hammerhead bumper. Use tabs @ orange arrows to retain harness.



3. Using OE hardware, install Hammerhead frame mounts in OE location. (both sides) Pull mounts away from truck and hand tighten nuts.

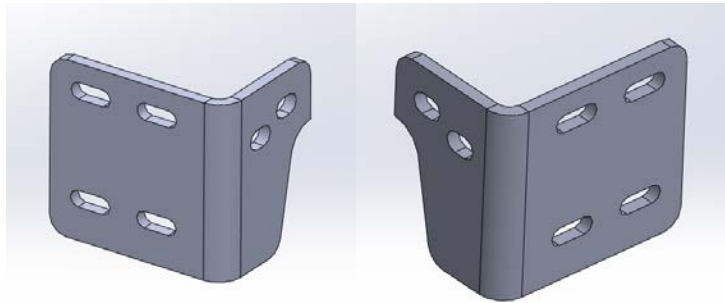

Left mount

Right mount

4. Install Hammerhead bumper on Hammerhead mounts using hardware kit #1. You will need eight 1/2"-13x2" bolts, 16 flat washers, 8 lock washers, 8 1/2"-13 nuts, and a 3/4" wrench and socket.
5. Align bumper and tighten all hardware.



Congratulations! Your product installation is now complete.
Thank you for your purchase.