

# 2009-20XX, FORD, F150

## BULL BAR INSTALLATION INSTRUCTIONS



# SAFETY

**Know safety, no injury. Know injury, no safety. ~Author Unknown**

If there are any questions, call 1-855-HHTOUGH

- **READ ALL SAFETY INSTRUCTIONS BEFORE INSTALLATION**
  - FOLLOW ALL INSTRUCTIONS FOR PROPER ASSEMBLY
  - WEAR APPROPRIATE EYE PROTECTION
  - EXERCISE CARE WHEN LIFTING COMPONENTS
  - USE APPROPRIATE TORQUE FOR BOLTS

### SUGGESTED TORQUE VALUES FOR STEEL GRADE SAE 5 BOLTS

BOLT DIAMETER (INCH)	TREADS PER INCH	TORQUE (POUND-FEET)
1/4	20	7
5/16	18	14
3/8	16	25
7/16	14	40
1/2	13	60
9/16	12	88
5/8	11	120
3/4	10	200
7/8	9	302
1	8	466

## I. PARTS LIST

ITEM NO.	QTY	PART NUMBER	DESCRIPTION	
1	1	600-56-0864	Standard Bullbar (All Lights)	-
1.1	1	60P-56-0864	600-56-0864 POLISHED	-
1.2	1	60K-56-0092	HARDWARE KIT #92 (B BAR MOUNT)	-
1.3	1	443-01-0086	LICENSE PLATE MOUNTING KIT	-
2	1	600-56-0877	BULL BAR MOUNT KIT	-
2.1	1	601-56-3750	LEFT FRAME MOUNT WELDMENT	-
2.2	1	601-56-3751	RIGHT FRAME MOUNT WELDMENT	-

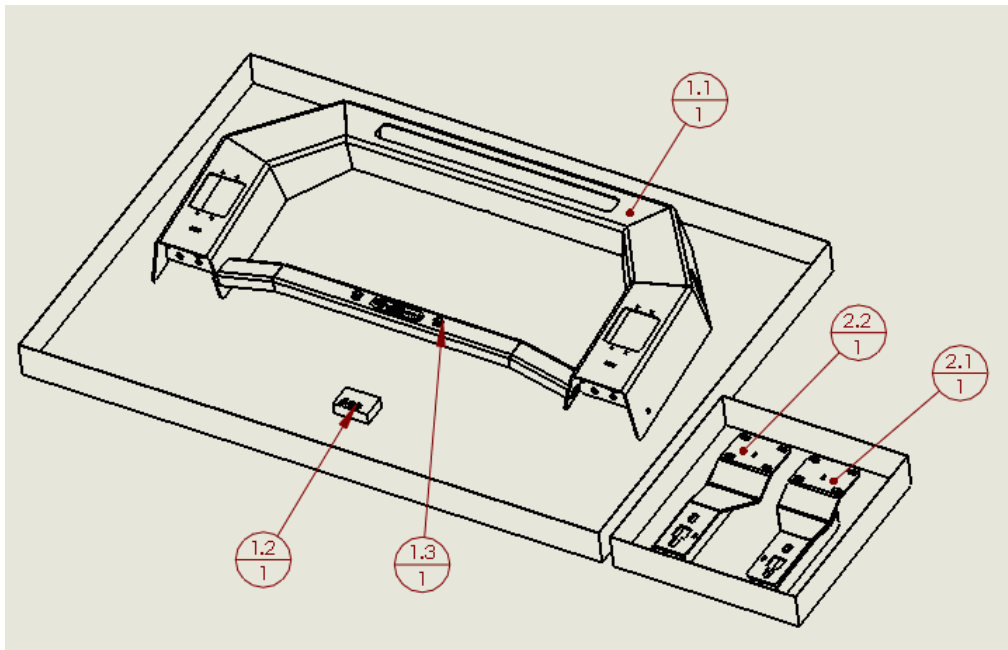

**REMOVE CONTENTS FROM BOX AND VERIFY ALL PARTS ARE PRESENT.**

If there are any questions, call 1-855-HHTOUGH or email [HHORDERS@hammerheadarmor.com](mailto:HHORDERS@hammerheadarmor.com)

## II. TOOL LIST

1. Basic tool set
2. 9/16" socket
3. 3" extension
4. 15mm socket
5. Flathead screwdriver

## III. PREPARE FOR BULL BAR INSTALLATION

1. Install lights in bull bar with provided hardware at this time.
2. Install license plate mounting kit if desired.

## 2009-2014 INSTRUCTIONS

### I. INSTALL BULL BAR

1. Locate the tow hooks underneath the front bumper.
2. Using a 15mm socket, loosen the rear tow hook bolt about half an inch. Next, remove the front tow hook bolt completely.



3. Remove the tow hooks by pushing back and then pulling down. (Both sides)
4. Layout frame mounts as shown:



5. Slide mounts over rear OE frame bolt and install front bolt. Do not fully tighten.



6. Lay down carpet or cardboard in front of truck. Layout Bull Bar as shown. Use hardware kit# 92 to attach bull bar to frame mounts. Use one 3/8"-16 bolt, one 3/8" lock washer, and one 3/8" flat washer per hole.



7. Switching back and forth from left side to right side, install one bolt at time. Once all bolts have been started, use a 9/16" socket with 3" extension and tighten all bolts. Use torque values on page one.
8. Using a 15mm socket, tighten the frame mounts.



Congratulations! Your product installation is now complete.  
Thank you for your purchase.

## 2015-20XX INSTRUCTIONS

### IV. INSTALL BULL BAR

1. Use a flathead screw driver to remove plastic trim around tow hook. Start at the rear and work your way around the sides. Once the sides are out, pull down on the trim to access the bolts. (both sides)



2. Using 15mm socket, loosen rear tow hook bolt. Screw it out about a half inch.
3. Using 15mm socket, remove front tow hook bolt.
4. Remove tow hook by pushing back and pulling down. (both sides)



5. Lay out Hammerhead frame mount and OE hardware as shown.



6. Slide mounts over rear OE frame bolt and install front bolt. Do not fully tighten.



7. Lay down carpet or cardboard in front of truck. Layout Bull Bar as shown. Use hardware kit# 92 to attach bull bar to frame mounts. Use one 3/8"-16 bolt, one 3/8" lock washer, and one 3/8" flat washer per hole. Install all bolts. Using a 9/16" socket with 3" extension, tighten all bolts. Use torque values on page one.



8. Route light wires down the uprights, and on top of the frame mounts into the truck's bumper. Secure them with zip ties.



Congratulations! Your product installation is now complete.  
Thank you for your purchase.