

JEEP JL 2018 - 20XX

RAVAGER REAR FLARE INSTALLATION INSTRUCTIONS



SAFETY

Know Safety, no injury. Know injury, no safety. ~Author Unknown

If there are any questions, call 1-855-HHTOUGH

- **READ ALL SAFETY INSTRUCTIONS BEFORE INSTALLATION**
 - FOLLOW ALL INSTRUCTIONS FOR PROPER ASSEMBLY
 - WEAR APPROPRIATE EYE PROTECTION
 - EXERCISE CARE WHEN LIFTING COMPONENTS
 - USE APPROPRIATE TORQUE FOR BOLTS
 - BLUE THREAD LOCKING COMPOUND IS RECOMMENDED ON ALL BOLTS

SUGGESTED TORQUE VALUES FOR STEEL GRADE SAE 5 BOLTS

BOLT DIAMETER (INCH)	TREADS PER INCH	TORQUE (POUND-FEET)
1/4	20	7
5/16	18	14
3/8	16	25
7/16	14	40
1/2	13	60
9/16	12	88
5/8	11	120
3/4	10	200
7/8	9	302
1	8	466



600-56-0827

I. PARTS LIST

ITEM NO.	QTY.	PART NUMBER	DESCRIPTION
1	1	601-56-3744	3048MM LENGTH FOAM ROLL
2	1	601-56-4483	3048MM LENGTH EDGE TRIM
3	1	60K-56-0108	HARDWARE KIT #108
4	1	60K-56-0170	HARDWARE KIT #170
5	1	60P-56-0827	LEFT REAR RAVAGER FLARE
6	1	60P-56-0828	RIGHT REAR RAVAGER FLARE

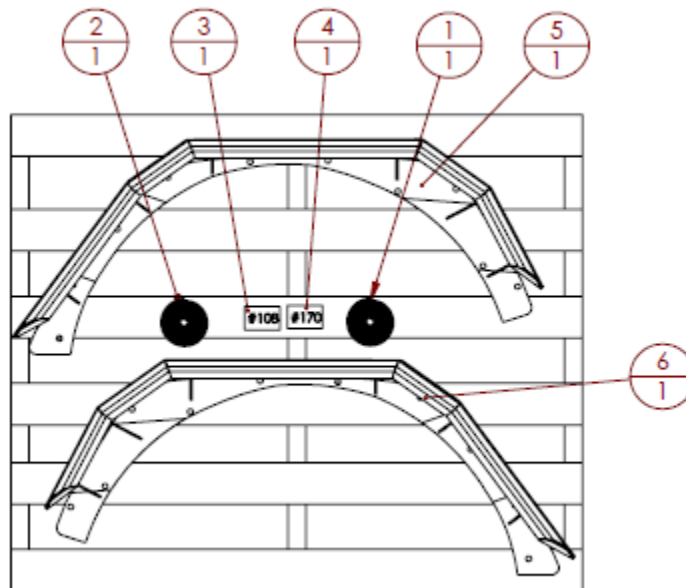

REMOVE CONTENTS FROM BOX AND VERIFY ALL PARTS ARE PRESENT.

If there are any questions, call 1-855 HHTOUGH or email HHORDERS@hammerheadarmor.com

II. TOOL LIST

1. A Good Friend
2. Basic Tool Kit
3. Torx 40 socket
4. 13mm wrench
5. 9/16" drill bit (step bit works best)
6. 17mm wrench

III. VEHICLE PREPARATION

1. Park vehicle on level surface and engage parking brake.
2. Remove the 6 christmas tree rivets in the inner fender of your rear flare. (save for later use)
3. Pull the rear flare outward, away from the body of the Jeep to remove it. It is designed with plastic clips which will detach when pulled.
4. Do this for both sides.

IV. RAVAGER REAR FLARE INSTALLATION

1. Using the step bit, drill out the indicated holes to 9/16"

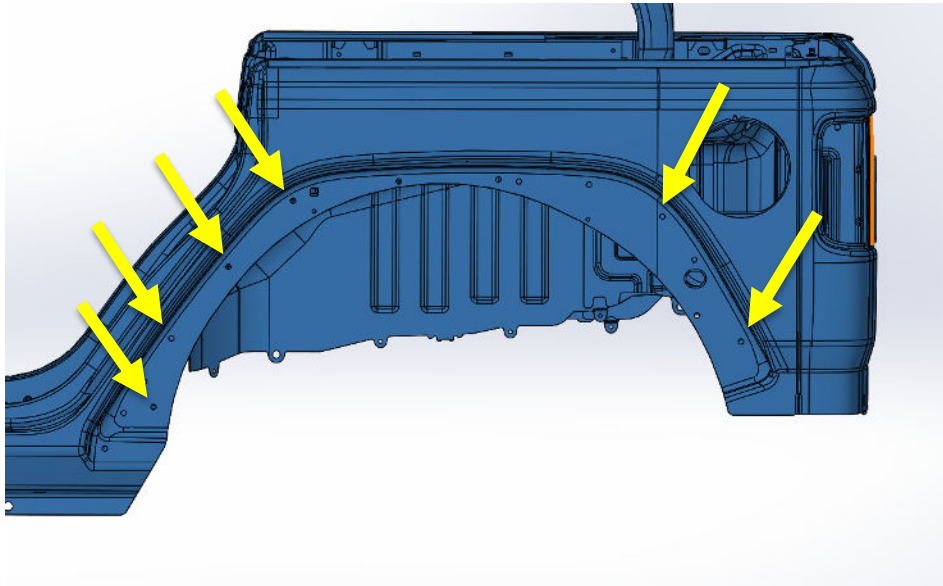

2. Install the six provided 8mm nutserts in the previously shown locations. (follow nutsert instructions on page 5)
3. Install the foam on the back of the flare as shown. Use 5ft total for each side.

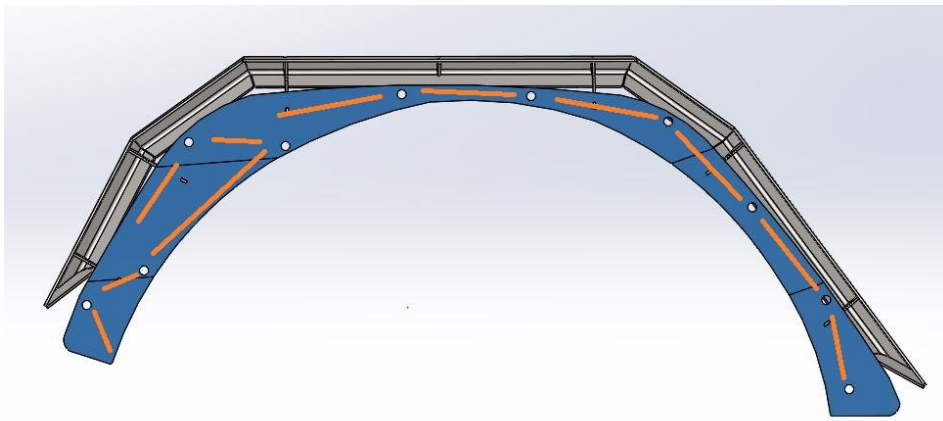

4. Cut the provided edge trim to fit and place it on the edge of the flare as shown.

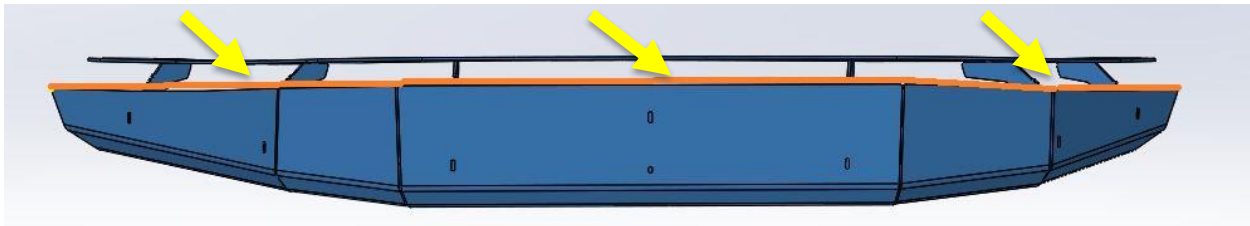

5. Using six of the provided 8mm Torx 40 bolts, install the flare on the Jeep. Do not tighten the bolts.
6. Use four 8mm Torx 40 bolts, 4 washers, and 4 nylock nuts in the other locations on the flare. Tighten all bolts with the torx 40 socket and the 13mm wrench.
7. Do this for both sides.

V. OE Inner Fender Installation

- a. Remove the rear inner fender from the flare.
- b. Once it is removed, reinstall it onto the Jeep as shown. You can use the body of the Jeep to mark for the cutting. Mark the inner fender along the body line all the way from the front to the back. **MAKE SURE TO SAVE THE TWO HOLES IN THE TOP FOR FUTURE USE** (indicated by the arrows, picture of finished product on next page)



- c. Cut the inner fender along the line you marked. A rotary tool is good for this job. **TAKE YOUR TIME** with the cut to produce a good visual result.

600-56-0827

- d. Use the OE Christmas tree rivets to reinstall the inner fender on the Jeep as shown.



- e. Do this for both sides.
f.

VI. NUTSERT INSTALLATION

- a. Take your time. Nutsert installation is not difficult if you take your time and use proper tools.
b. The picture below shows the provided nutsert tool and how to assemble it. (Hardware kit #108)



- c. Start by drilling a pilot hole, using a 1/8" drill bit.
d. After drilling the pilot hole use a 9/16" drill bit to drill out the final hole size. A step drill bit works much better than a standard 9/16" bit.



- e. Once you have the hole drilled, thread the nutsert onto the nutsert tool and insert into the hole.



600-56-0827

- f. Turn the 13mm wrench while holding the nut with the 17mm wrench until the nutsert is installed. (4 rotations of the 13mm is roughly how tight it should be for install. You could mark the socket or bolt to know how many rotations you have made.)



- g. Overtightening the nutsert will make it fail. Make sure not to do this.



**Congratulations! Your Installation is now complete.
Thank You for your purchase!**