

2019-20XX CHEVY 1500 WINCH – SHEETMETAL BGUARD

FRONT BUMPER INSTALLATION INSTRUCTIONS



SAFETY

Know Safety, no injury. Know injury, no safety. ~Author Unknown

If there are any questions, call 1-855-HHTOUGH

- **READ ALL SAFETY INSTRUCTIONS BEFORE INSTALLATION**
 - FOLLOW ALL INSTRUCTIONS FOR PROPER ASSEMBLY
 - WEAR APPROPRIATE EYE PROTECTION
 - EXERCISE CARE WHEN LIFTING COMPONENTS
 - USE APPROPRIATE TORQUE FOR BOLTS
 - BLUE THREAD LOCKING COMPOUND IS RECOMMENDED ON ALL BOLTS

SUGGESTED TORQUE VALUES FOR STEEL GRADE SAE 5 BOLTS

BOLT DIAMETER (INCH)	TREADS PER INCH	TORQUE (POUND-FEET)
1/4	20	7
5/16	18	14
3/8	16	25
7/16	14	40
½	13	60
9/16	12	88
5/8	11	120
¾	10	200
7/8	9	302
1	8	466



600-56-0841

I. PARTS LIST

ITEM NO.	QTY	PART NUMBER	DESCRIPTION	
1	4	316-01-0005	1.25" PLUG BT-FLUSH LDPE BLACK	-
2	2	601-56-2868	WELDNUT TAB 3	-
3	1	601-56-5027	RIGHT FRAME MOUNT WELDMENT	-
4	1	601-56-5028	LEFT FRAME MOUNT WELDMENT	-
5	1	60A-56-0856	600-56-0856 POLISHED	-
6	1	60K-56-0058	HARDWARE KIT #58	-

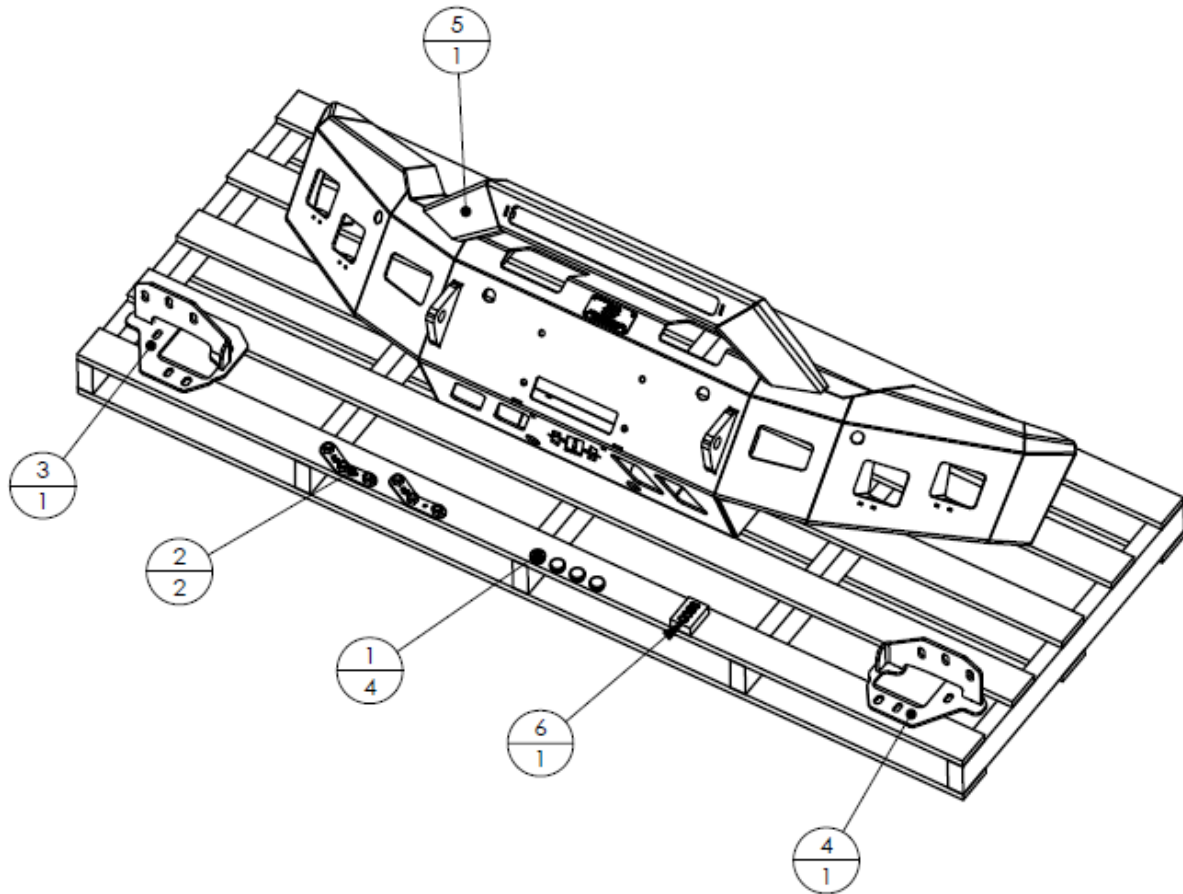

REMOVE CONTENTS FROM BOX AND VERIFY ALL PARTS ARE PRESENT.

If there are any questions, call 1-855 HHTOUGH or email HHORDERS@hammerheadarmor.com



600-56-0841

II. TOOL LIST

1. A Good Friend
2. Basic Tool Kit
3. Blue Masking Tape
4. Trim Tool
5. T-15 Torx bit
6. 10mm socket
7. 15mm socket
8. 12" extension
9. 18mm socket
10. 3/4" socket
11. 3/4" wrench

III. VEHICLE PREPARATION

1. Park vehicle on level surface.
2. Engage parking brake and disconnect battery.
3. Using blue masking tape, mask along the profile of your truck above the bumper. This will help protect your truck from any accidental scratches.

IV. REMOVAL OF OE BUMPER

1. Open hood. Using a T15 Torx bit, remove two screws attaching hood latch release lever to latch. Remove latch and set aside. It will be reused.

NOTE: DO NOT CLOSE THE HOOD UNTIL THIS LEVER HAS BEEN REPLACED.



2. Using a trim tool, remove ten clips from engine shroud. Remove shroud and set aside. It will be reused.

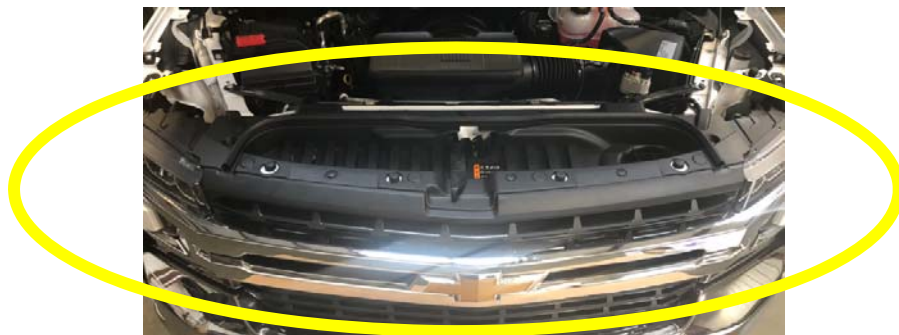

- Using a 10mm socket, remove four screws attaching top of grill to core support.



- Using your hand, pick up on the top of the grill and pull away from the truck. This will disengage tabs on the top of the grill and allow the top of the grill to move away from the core support.



- Gently pull out on the center of the grill near the emblem to disengage the tab attaching the center of the grill to the core support.
- Gently pull out on the bottom of the grill to disengage the tabs on the bottom of the grill. Set grill aside. It will be reused.

- Using trim tool, remove eight Christmas trees from the shroud on the bottom of the louver assembly.



- Using 15mm socket, remove three bolts attaching side brace to bumper/frame. Remove brace and set aside. It will not be reused. (both sides)



9. Using 10mm socket, remove bolts attaching bottom brace to bumper/frame. Remove brace and set aside. (both sides)

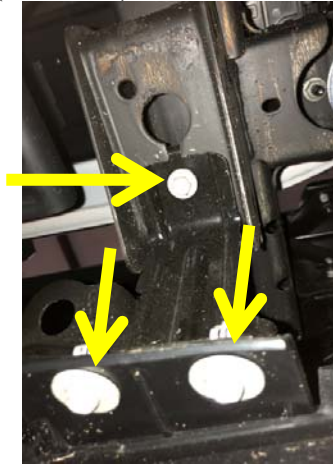

10. Using 18mm socket and 12" extension, remove four bolts attaching OE bumper to frame. Remove bumper and set aside. It will not be reused.



11. Using 15mm socket, remove six bolts attaching OE bumper mounts to frame. Remove mounts and set aside. They will not be reused. (both sides)

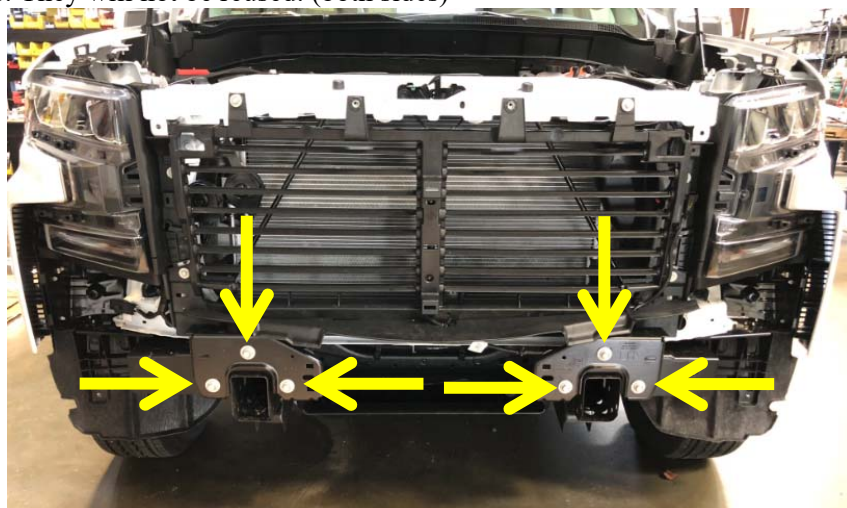



600-56-0841

12. Replace the following parts.
 - A. Lower trim on louver assembly
 - B. Grill
 - C. Engine shroud
 - D. Hood latch lever, close hood

V. INSTALLATION OF HAMMERHEAD BUMPER

1. Lay bumper face down on a carpeted surface or piece of cardboard. Install winch and or all lights in bumper using brackets and hardware provided by manufacturer.
2. Install OE sensor grommets and sensors in corresponding location in HH bumper. (if applicable) For bumpers without sensors, install plastic plugs.
3. Lay out frame mounts and OE hardware as shown.



4. Install frame mounts using OE hardware as shown. The bumper's left and right adjustment is made with these bolts. Do not fully tighten.





600-56-0841

5. Using a hoist or a few friends, attach bumper to frame mounts using hardware kit #58 and weldnut tab 3. Start all bolts before aligning bumper. Leave a minimum of 3/8" space between bumper and truck body. When the truck flexes off-road, this distance allows your bumper and truck body to have clearance. Tighten bolts with 3/4" socket or wrench. Tighten frame mount bolts at this time. Torque all hardware to specs on page one.



**Congratulations! Your Installation is now complete.
Thank You for your purchase!**