



600-56-0884

## JEEP JL 2018 - 20XX

### REAR FLARE DELETE INSTALLATION INSTRUCTIONS



# SAFETY

**Know Safety, no injury. Know injury, no safety. ~Author Unknown**

If there are any questions, call 1-855-HHTOUGH

- **READ ALL SAFETY INSTRUCTIONS BEFORE INSTALLATION**
  - FOLLOW ALL INSTRUCTIONS FOR PROPER ASSEMBLY
  - WEAR APPROPRIATE EYE PROTECTION
  - EXERCISE CARE WHEN LIFTING COMPONENTS
  - USE APPROPRIATE TORQUE FOR BOLTS
  - BLUE THREAD LOCKING COMPOUND IS RECOMMENDED ON ALL BOLTS

#### **SUGGESTED TORQUE VALUES FOR STEEL GRADE SAE 5 BOLTS**

BOLT DIAMETER (INCH)	TREADS PER INCH	TORQUE (POUND-FEET)
1/4	20	7
5/16	18	14
3/8	16	25
7/16	14	40
1/2	13	60
9/16	12	88
5/8	11	120
3/4	10	200
7/8	9	302
1	8	466



600-56-0884

## I. PARTS LIST

ITEM NO.	QTY	PART NUMBER	DESCRIPTION
1	1	601-56-5129	LEFT REAR FLARE DELETE
2	1	601-56-5130	RIGHT REAR FLARE DELETE
3	1	60K-56-0184	HARDWARE KIT #184

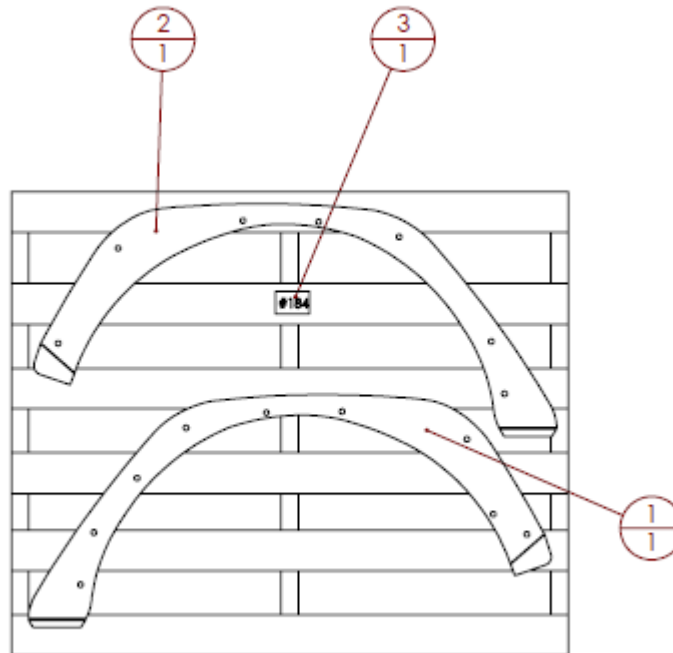

**REMOVE CONTENTS FROM BOX AND VERIFY ALL PARTS ARE PRESENT.**

If there are any questions, call 1-855 HHTOUGH or email [HHORDERS@hammerheadarmor.com](mailto:HHORDERS@hammerheadarmor.com)

## II. TOOL LIST

1. A Good Friend
2. Basic Tool Kit
3. Torx 40 socket
4. 13mm wrench
5. 9/16" drill bit (step bit works best)
6. 17mm wrench



600-56-0884

### III. VEHICLE PREPARATION

1. Park vehicle on level surface and engage parking brake.
2. Remove the 6 christmas tree rivets in the inner fender of your rear flare. (save for later use)
3. Pull the rear flare outward, away from the body of the Jeep to remove it. It is designed with plastic clips which will detach when pulled.
4. Do this for both sides.

### IV. FLARE DELETE INSTALLATION

1. The Flare Delete installs with 2 different spacers and bolt lengths. The 5/16" spacers and the 3/4" length bolts are located as shown below.
2. Using the step bit, drill out the indicated holes to 9/16"

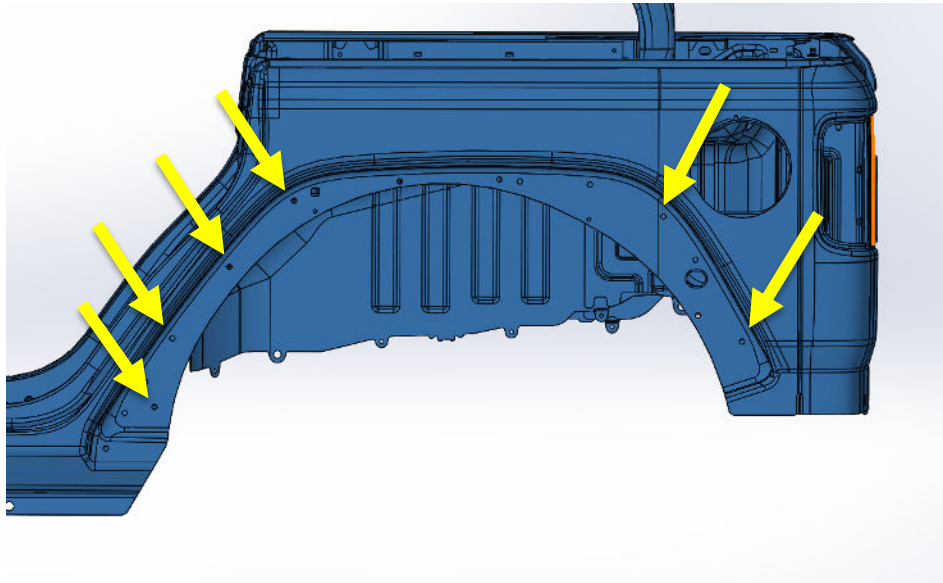

3. Install the six provided 8mm nutserts in the previously shown locations. (follow nutsert instructions on page 5)
4. Using six of the provided 8mm Torx 40 bolts and 1/2" spacers, install the Flare Delete on the Jeep at the nutsert locations. Do not tighten the bolts.
5. Use four 8mm Torx 40 bolts, four 1/2" spacers, 4 washers, and 4 nylock nuts in the other locations on the flare. Tighten all bolts with the torx 40 socket and the 13mm wrench.
6. The Flare Delete has slight adjustment. Adjust until it is not touching the Fender of the Jeep in any locations.
7. Tighten all hardware to 14ft-lbs
8. Do this for both sides.



600-56-0884

## V. OE Inner Fender Installation

- a. Remove the rear inner fender from the flare.
- b. Once it is removed, reinstall it onto the Jeep as shown. You can use the body of the Jeep to mark for the cutting. Mark the inner fender along the body line all the way from the front to the back. **MAKE SURE TO SAVE THE TWO HOLES IN THE TOP FOR FUTURE USE**



- c. Cut the inner fender along the line you marked. A rotary tool is good for this job. **TAKE YOUR TIME** with the cut to produce a good visual result.
- d. Use the OE Christmas tree rivets to reinstall the inner fender on the Jeep as shown.



- e. Do this for both sides.



600-56-0884

## VI. NUTSERT INSTALLATION

- a. Take your time. Nutsert installation is not difficult if you take your time and use proper tools.
- b. The picture below shows the provided nutsert tool and how to assemble it. (Hardware kit #108)



- c. Start by drilling a pilot hole, using a 1/8" drill bit.
- d. After drilling the pilot hole use a 9/16" drill bit to drill out the final hole size. A step drill bit works much better than a standard 9/16" bit.



- e. Once you have the hole drilled, thread the nutsert onto the nutsert tool and insert into the hole.
- f. Turn the 13mm wrench while holding the nut with the 17mm wrench until the nutsert is installed. (4 rotations of the 13mm is roughly how tight it should be for install. You could mark the socket or bolt to know how many rotations you have made.)



- g. Overtightening the nutsert will make it fail. Make sure not to do this.



600-56-0884

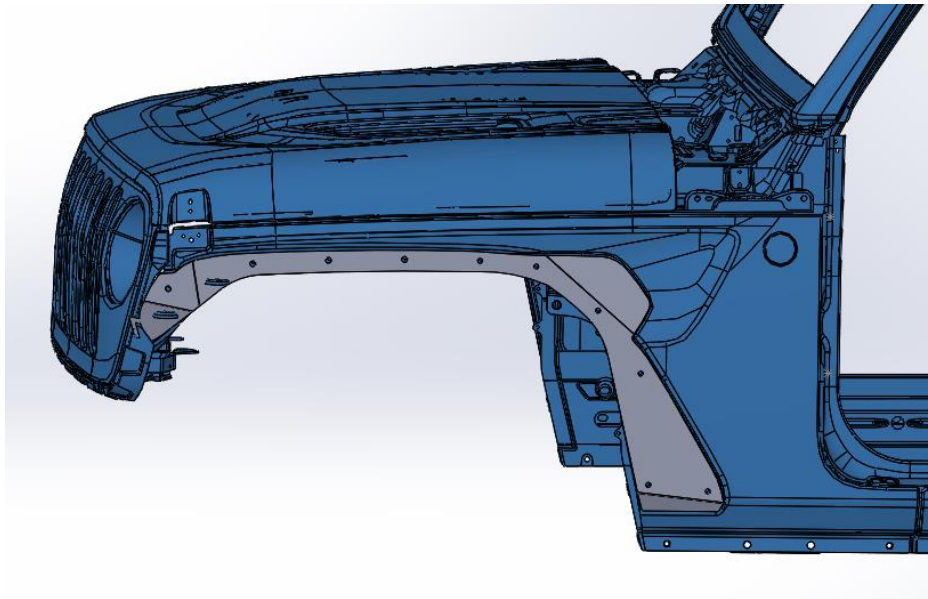

**Congratulations! Your Installation is now complete.  
Thank You for your purchase!**