

2014-2018 CHEVY-GMC 1500 TRUCK RAILS

INSTALLATION INSTRUCTIONS



SAFETY

Know Safety, no injury. Know injury, no safety. ~Author Unknown
If there are any questions, call 1-855-HHTOUGH

- **READ ALL SAFETY INSTRUCTIONS BEFORE INSTALLATION**
 - FOLLOW ALL INSTRUCTIONS FOR PROPER ASSEMBLY
 - WEAR APPROPRIATE EYE PROTECTION
 - EXERCISE CARE WHEN LIFTING COMPONENTS
 - USE APPROPRIATE TORQUE FOR BOLTS
 - BLUE THREAD LOCKING COMPOUND IS RECOMMENDED ON ALL BOLTS





600-56-0933

Suggested Torque Values For Steel Grade 5 Standard Bolts

BOLT DIAMETER (INCH)	THREADS PER INCH	TORQUE (POUND - FEET)
1/4	20	7
5/16	18	14
3/8	16	25
7/16	14	40
1/2	13	60
9/16	12	88
5/8	11	120
3/4	10	200
7/8	9	302
1	8	466

Suggested Torque Values For Steel Grade 8.8 Metric Bolts

BOLT DIAMETER (mm)	THREAD PITCH (mm)	TORQUE (POUND-FEET)
6	1.0	7
8	1.25	16
10	1.5	32
12	1.75	55
14	2.0	88
16	2.0	140
18	2.5	195
20	2.5	275
22	2.5	375
24	3.0	475

I. TRUCK RAIL PARTS LIST

ITEM NO.	QTY	PART NUMBER	DESCRIPTION
1	1	601-56-3744	3048MM LENGTH FOAM ROLL
2	4	601-56-3942	FRONT STEP PLATE
3	2	601-56-5110	FRONT ACCENT PLATE
4	2	601-56-5111	MIDDLE ACCENT PLATE
5	2	601-56-5112	REAR ACCENT PLATE
6	4	601-56-5113	ROCK LIGHT BRACKET
7	1	60K-56-0181	HARDWARE KIT #181
8	1	60K-56-0182	HARDWARE KIT #182
9	1	60P-56-0860	LEFT RAIL WELDMENT
10	1	60P-56-0861	RIGHT RAIL WELDMENT

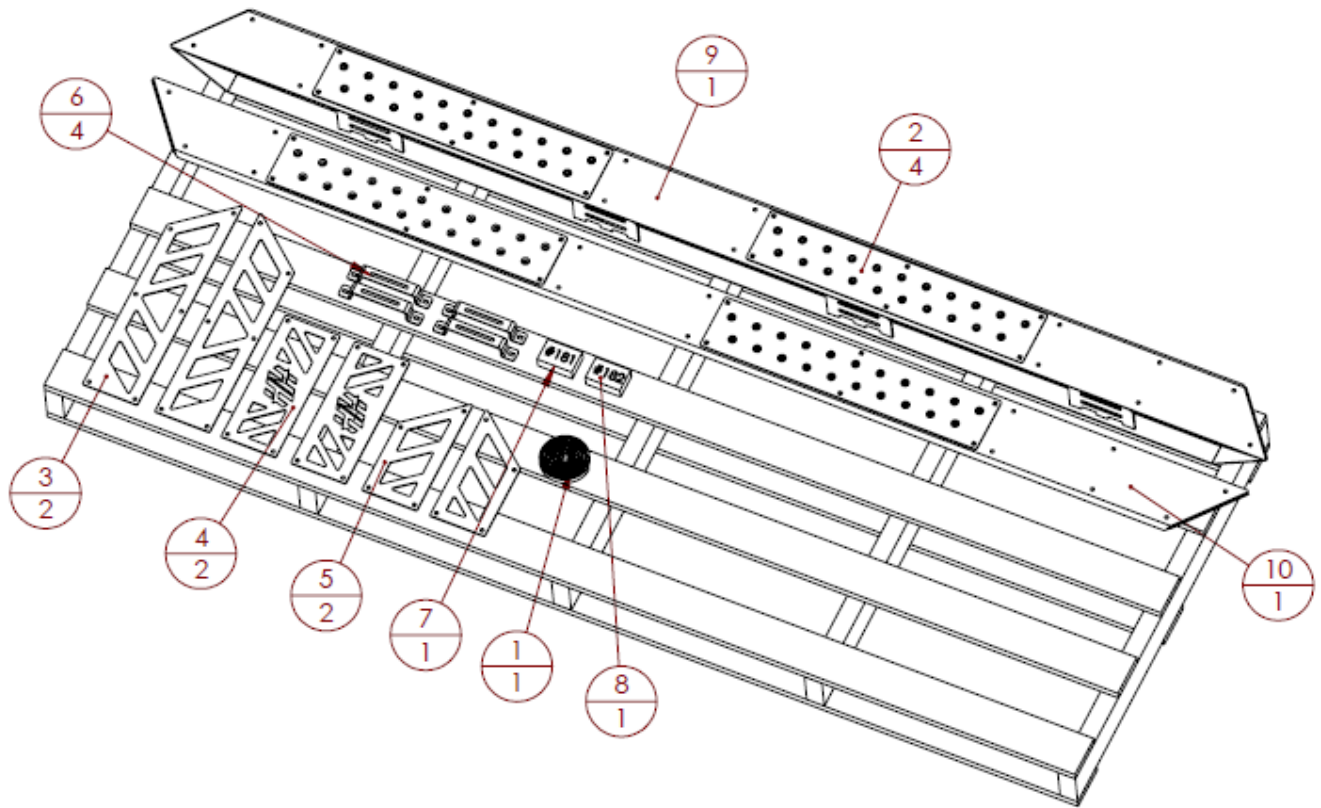

II. MOUNT PART LIST

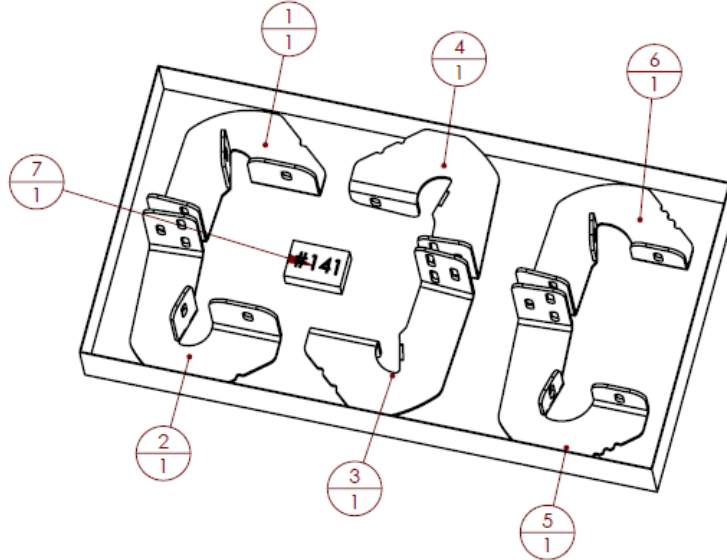

ITEM NO.	QTY	PART NUMBER	DESCRIPTION
1	1	601-56-5266	FRONT LEFT MOUNT WELDMENT
2	1	601-56-5267	FRONT RIGHT MOUNT WELDMENT
3	1	601-56-5268	MIDDLE LEFT MOUNT WELDMENT
4	1	601-56-5269	MIDDLE RIGHT MOUNT WELDMENT
5	1	601-56-5270	REAR LEFT MOUNT WELDMENT
6	1	601-56-5271	REAR RIGHT MOUNT WELDMENT
7	1	60K-56-0141	HARDWARE KIT #141

REMOVE CONTENTS FROM BOX AND VERIFY ALL PARTS ARE PRESENT.

If there are any questions, call 1-855 HHTOUGH or email HHORDERS@hammerheadarmor.com

TOOL LIST

1. A Good Friend
2. Basic Tool Kit
3. 5/16" electric impact
4. T30 Torx bit
5. 7/16" wrench
6. 13mm socket
7. 9/16" socket

III. VEHICLE PREPARATION

1. Park vehicle on level surface.
2. Engage parking brake and disconnect battery.
3. Remove any installed running boards or steps.

IV. ASSEMBLY OF HH TRUCK RAILS

1. If you want to paint your accent plates and/or steps, do so now. Allow paint to fully cure before assembly.
2. Lay truck rails on a carpeted surface or piece of cardboard.
3. Using scissors, cut strips of foam to go between bolt holes on the bottom of all steps and accent plates. Layout all accent plates in the orientation they go and make sure to apply foam strips on the back surface. NOTE: The foam strips are very difficult to remove once applied.
4. Using hardware kit #182, T30 torx bit and 7/16" wrench, install accent plates and steps at this time. An electric impact makes this a quick and easy task.
5. If you are going to install rock lights, they need to be installed after the rails are installed on the truck for proper wire routing.
6. Your truck rails are now assembled and ready to be installed.



Left rail shown above – small accent plate goes toward the front of the truck (accent plates and steps shown in red)

VI. INSTALLATION OF HH TRUCK RAILS

1. On left side of truck, layout mounts and hardware kit #141. There are three different mounts that will be used. Part # 5266 has one notch on the back of it and it goes at the front of the cab. Part # 5268 has two notches on the back of it and it goes in the middle of the cab. Part # 5270 has three notches on the back of it and it goes at the back of the cab.

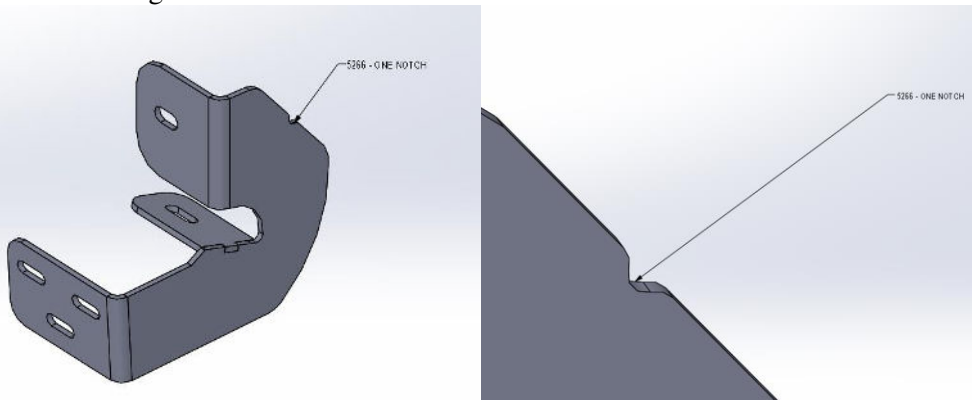

Part # 5266

600-56-0933

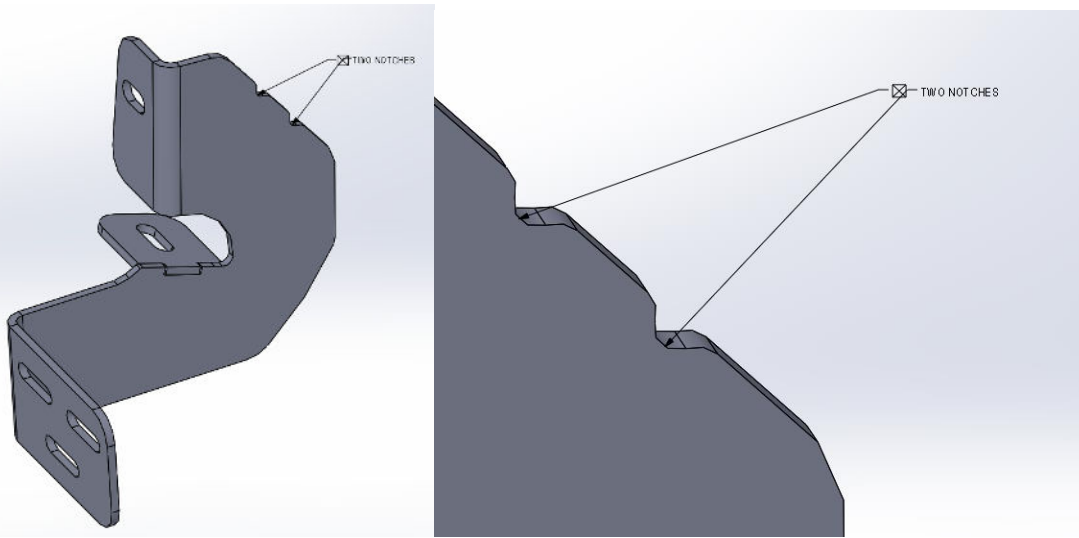

Part # 5268

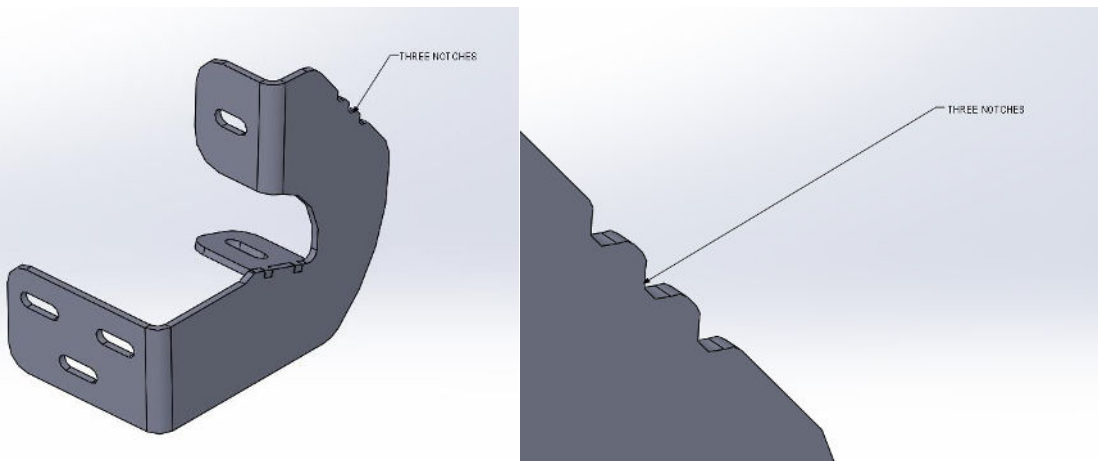

Part # 5270

2. Use two M8 bolts, two lock washers, and two flat washers on the front two mounts. Attach them to the truck's body. Use the front two sets of holes and the rearmost set of holes for the mounts. Use a 13mm socket; do not fully tighten.



600-56-0933

3. On the rear mount, install spring nuts from hardware kit # 141 in existing cab holes for rear two mounts. You may need to remove tape or plastic plugs covering the holes.

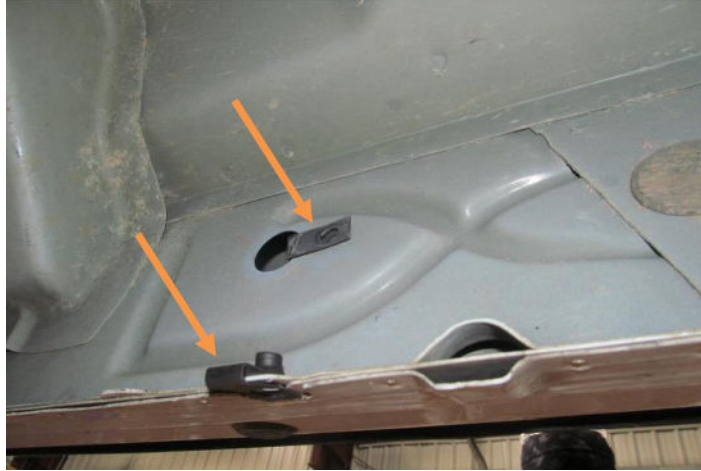

4. In this step you will use hardware from kit #182. It has 3/8" carriage head bolts that will be installed from the inside of the rail. Have a friend help you hold the truck rail up to the mount's surface. Install one carriage head bolt on the front mount and one on the rear mount. This will make it easy to install the remaining bolts attaching the rail to the mounts. Use one flat washer, lock washer, and one nut on each carriage head bolt. Make sure to mount the rail at least 1/2" from the front mud flap. Tighten rail and frame mounts at this time with 9/16" socket.

5. Repeat for other side.



Congratulations! Your Installation is now complete.

Thank You for your purchase!